

SOUND ABSORPTION PANELS

MECART

DESCRIPTION

MECART acoustic panels are manufactured in our own factory, allowing us to engineer panels that can meet any noise reduction and reverberation control requirements.

Our design process is driven by your technical needs and specifications, ensuring precise control over:

- Insulation properties
- Sound absorption coefficients
- Custom dimensions
- Finish and coating options

APPLICATION

- Studios
- Meeting/conference rooms
- Restaurants
- Auditoriums
- Houses of Worship
- Mechanical rooms
- Factories
- Gymnasiums

ADVANTAGES

- Noise reduction and control of reverberation
- Elegant look
- Durable and impact resistant
- Suitable for indoor and outdoor installations
- Easy to install
- Color matching options
- Non-combustible

FINISH

Powder coating with a wide range of paint colors

COMPOSITION

22 gauge perforated galvanized steel with customizable acoustic insulation*

OPTIONS

- Heavier gauge available
- Color matching
- Custom dimensions
- Insulation cover layer

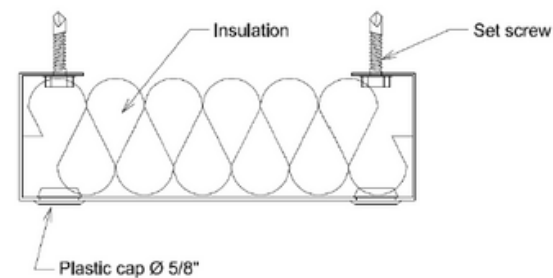
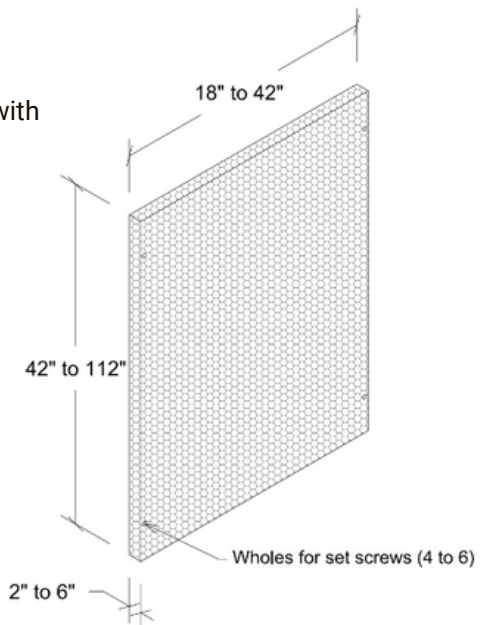
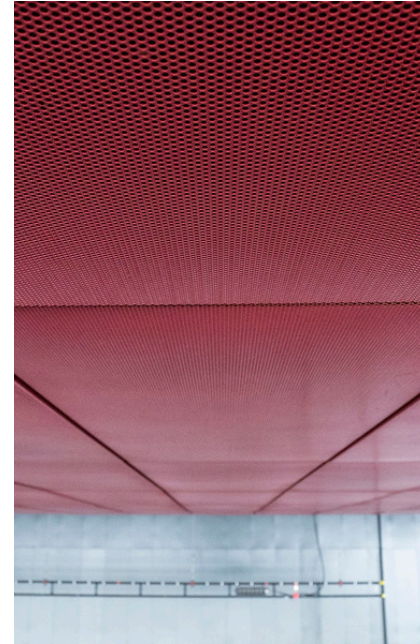

Thickness	Absorption coefficient @ octave band frequency (Hz)*							NRC
	63	125	250	500	1000	2000	4000	
2" (52mm)	-	0.25	0.51	0.85	0.97	1.00	1.03	0.85
6" (153mm)	-	1.09	1.45	1.26	1.13	1.11	1.1	1.25

*Based on the performance of 1.1 lb/ft³ fiberglass (A mounting), variable insulation available as option

Note: This datasheet is subject to change without notice.